

FORESTRY MULCHERS

UMH/S - UMH/S/HP

Forestry mulchers for PTO tractors with fixed tooth rotor.

The UMH is FAE's top of the line tractor mounted forestry mulcher. It is rated for trees up to 45 cm diameter and is designed to work with high horsepower tractors. The hydrodynamic joints and the Spike Pro counter-blades guarantee optimal performance and productivity. The ergonomics of the new, fully enclosed double layer "dustproof"

frame is designed for maximum safety of the work and the operator. Finally, the large diameter of the rotor and the new Spike Pro counter-blades provide excellent homogenous shredding results. Backed by FAE's unparalleled engineering expertise, UMH/S/HP is built to last and delivers the maximum return on your investment.

 240-500 hp

 Ø 45 cm max

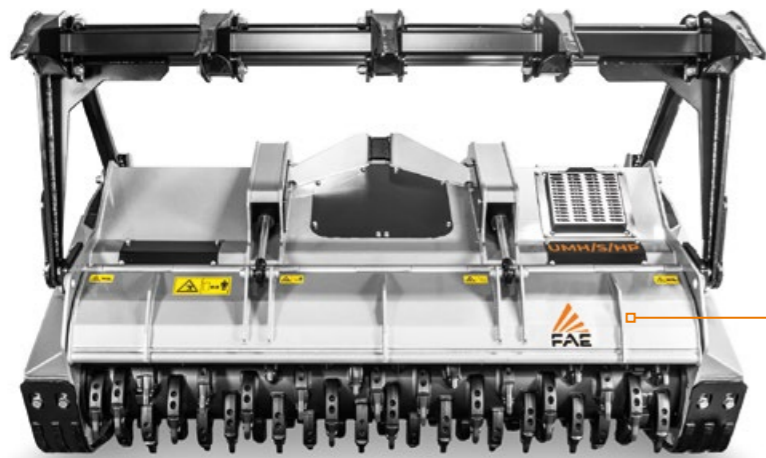

Spike Control Pro and their distribution produce a finer shredding result



Centralized greasing hub for easier maintenance



Adjustable extended 3 point hitch fits perfectly with any kind of tractor

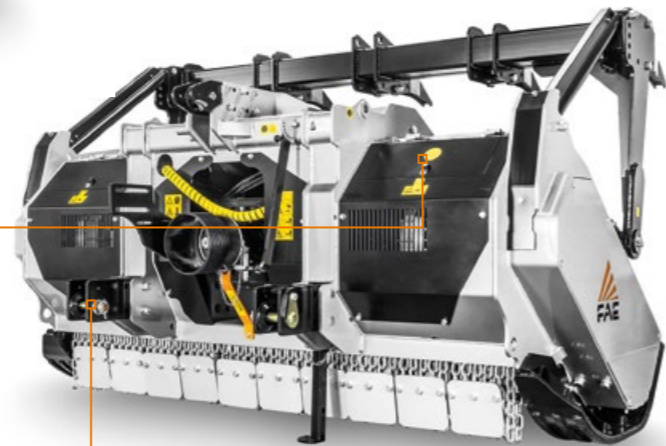

MAIN OPTIONS



W style self-aligning device between PTO drive shaft/gearbox allows the mulcher to work at several angles without damaging the PTO



Mechanical/hydraulic push frame guides and pushes material away from carrier



Additional ripper for push frame helps with the positioning of standing material while mulching



Standard hydraulic clutch transmission protects the transmission at PTO engagement for smooth starting and improves machine performance

STANDARD EQUIPMENT

Hydraulic rear hood	Gearbox with oil cooling system (UMH/S/HP)
Inner anti wear clad plates FCP (UMH/S)	PTO shaft
Adjustable extended 3 point linkage	Cam clutch on side PTO (UMH/S)
Enclosed machine body	Bolted-on rotor shafts (in forged steel)
Centralized greasing hub	Hydraulic top link
Hydraulic hoses integrated in the frame	Z style self ranging system of the PTO drive shaft/gearbox
Cylinder protection	Forged and hardened interchangeable counter-blades (UMH/S)
Bolted on protection chains	Third row of interchangeable forged and hardened counter-blades (UMH/S)
Transmission with belts (UMH/S)	Interchangeable bolted on spike PRO counter-blade (UMH/S/HP)
Poly-Chain® belts transmission (UMH/S/HP)	Adjustable skids
Hydraulic clutch transmission (UMH/S/HP)	Supporting service leg
Gearbox with freewheel	

OPTIONS

Bolt-on chain's protection plates	Special skids to go underground
Hydraulic clutch transmission (UMH/S)	Mechanical guard frame
Multiple tooth options	Hydraulic guard frame
W style self-aligning device between PTO drive shaft/gearbox	Extra ripper for guard frame
Interchangeable bolted on spike counter-blade (UMH/S)	

MODEL	UMH/S 225	UMH/S 250	UMH/S/HP 225	UMH/S/HP 250
Tractor (hp)	240-400	250-400	350-500	350-500
PTO (rpm)	1000	1000	1000	1000
Working width (mm)	2320	2560	2320	2560
Total width (mm)	2820	3060	2760	3000
Weight including rotor type C/3 (kg)	4050	4290	5100	5200
type A/3 (kg)	4360	4510	5400	5500
Rotor diameter (mm)	680	680	680	680
Max shredding diameter (mm)	400	400	450	450
No. teeth type A/3+MH	88+2	96+2	88+2	96+2
type C/3+C/3/SS	54+2	60+2	54+2	60+2

Data refers to machine as standard. The technical data in this catalogue may be altered without prior notice.

ROTOR TYPE A



ROTOR TYPE C

